

# FT FELLING TRAILERS®

## Chopper Trailers



**FT-40S-A Chopper** (shown with optional 30" ramps)



**FT-40S-A Chopper** with standard dovetail, optional wood inlay beavertail and pressure treated wood deck.



**FT-40S-A Chopper** with optional 30" ramps, wood inlay beavertail and pressure treated wood deck.

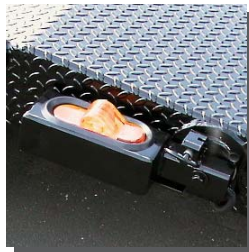

Shown above are the flip-up/down tail lights, flip lights down to allow clearance when loading and then flip to upright position for transport.



Shown above are the optional Traction Bars that go up and over the fenders providing additional grip and stability when loading and in transit.

The **FELLING** Style:  
Quality ~ Craftsmanship ~ Pride

1-800-245-2809 • [www.felling.com](http://www.felling.com)

Email: [trailers@felling.com](mailto:trailers@felling.com) • Fax: (320) 352-5230 • 1525 Main Street South, Sauk Centre, MN 56378

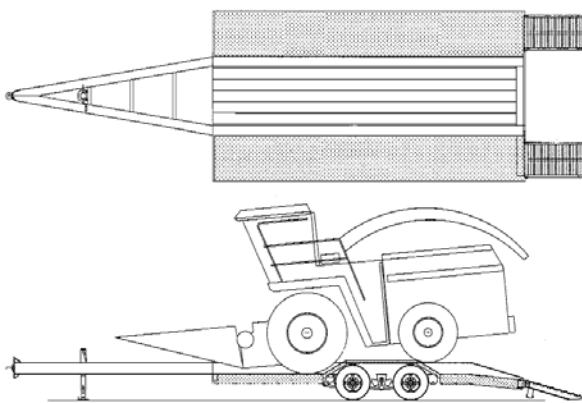
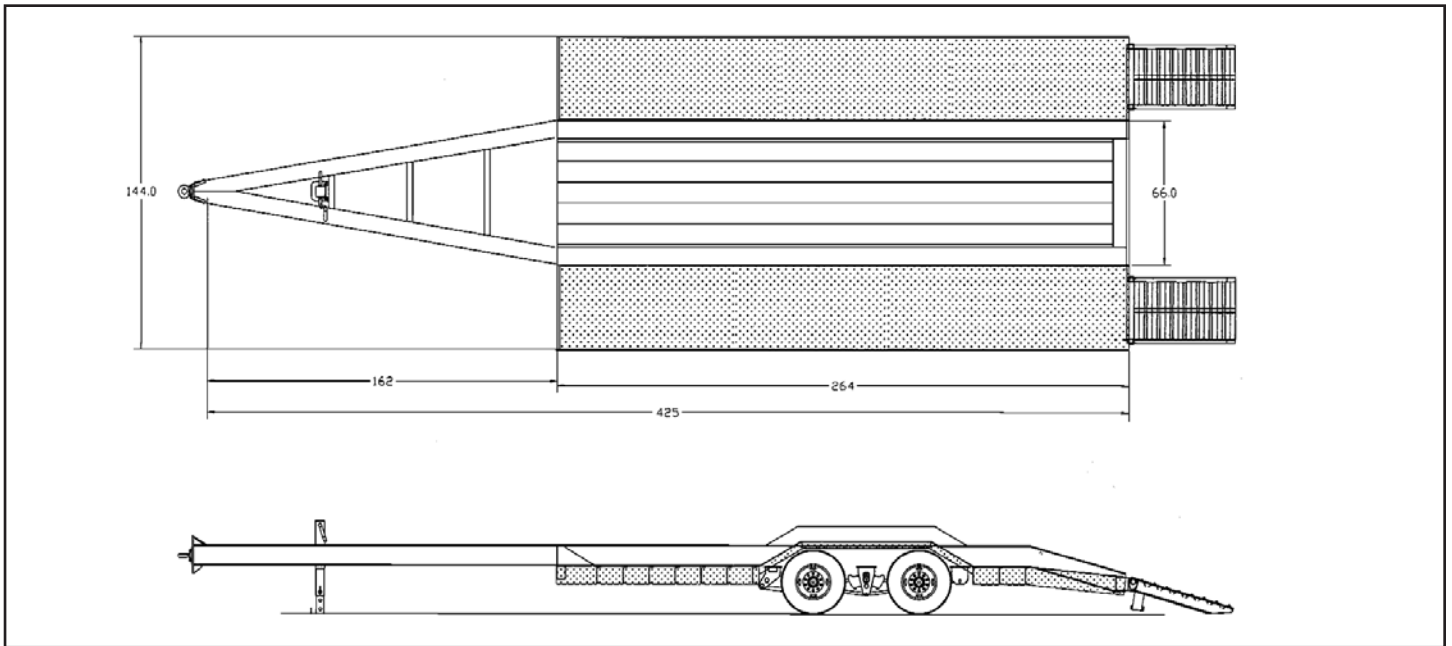

Chopper/Sprayer Trailer loaded  
with New Holland Chopper

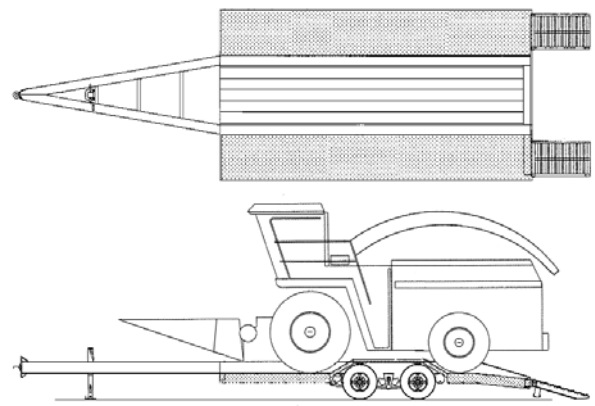

Chopper/Sprayer Trailer loaded  
with John Deere Chopper

## STANDARD FEATURES:

- 40,000# (18,143 kg) GVWR
- (2) 25,000# oil bath axles
- (8) 215/75R17.5 LRH Radial tires
- (8) 10 Hole dual Budd Wheels
- Cap. per tire & wheel 4,540 lb. (2,059 kg)
- Spring axle with 9700 Hutch Suspension
- ABS Air Brakes - All Wheels
- Lunette eye
- 25,000# 2-speed adj. drop foot jack
- Tool box (with lockable cover)
- (8) D-rings
- Traction bars up, over and in front on fenders
- D.O.T. approved LED lighting

**1-800-245-2809 • [www.felling.com](http://www.felling.com)**

Email: [trailers@felling.com](mailto:trailers@felling.com) • Fax: (320) 352-5230 • 1525 Main Street South, Sauk Centre, MN 56378