



ISO 9001 Quality Management System | WBENC-Certified WBE | THE TRAILER EXPERTS - SINCE 1974

### Product Sheet

Felling Trailers, Inc. 2021

www.felling.com • 1-800-245-2809

1525 Main Street South

Sauk Centre, MN 56378

<b>FT-16-2 DT</b>		<b>Deck Over Dump Series</b>	
<b>GVWR LBS: 18,400</b>	<b>GAWR LBS: 16,000</b>	<b>WEIGHT LBS: 5,300</b>	<b>CAPACITY LBS: 13,100</b>

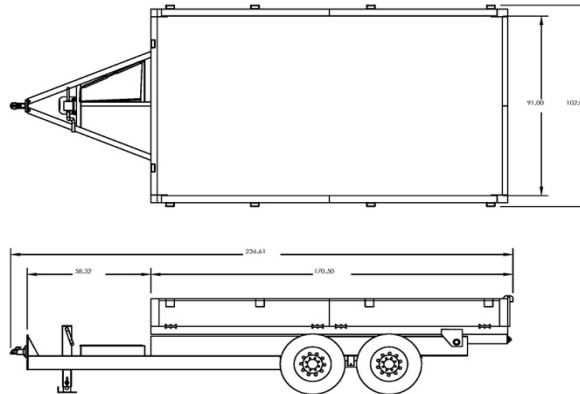

Feature Name	Standard Features	Std. Qty	UOM
<b>Model</b>	<b>FT-16-2 DT</b>	1	
<b>Deck Length</b>	Add Deck Length	14	Feet
<b>Deck Type</b>	7 Gauge Floor with 10 Gauge 20" Sides	1	Std
<b>Ramps, Acc</b>	No Ramps	1	Opt
<b>Rear Gate</b>	Barn Door Assembly	1	Std
<b>Appx Deck Height</b>	38" Loaded, 40" Unloaded	1	Inches
<b>Width</b>	102" OD, 91" ID	1	Std
<b>Tie Downs</b>	Stake Pockets	10	Std
<b>Brakes</b>	Electric, FSA (Fwd Self Adj) On All Axles	1	Std
<b>Axles</b>	8K Oil Bath Straight	2	Std
<b>Suspension</b>	Spring	1	Std
<b>Tires &amp; Wheels</b>	215/75R 17.5 H, 8 Bolt [17.5 x 6.75] Plate Wheel	4	Each
<b>Hitch Length</b>	Center of Coupler to Headboard, Appx	5	Feet
<b>Hitch Type</b>	2.5" Adjustable Lunette Eye/Pintle, [C] 42,000 lb Plate Mount (5/8" Bolt)	1	Std
<b>Jack</b>	12K w/ Spring Loaded Drop Leg, Side Wind	1	Std
<b>Plug</b>	7 Pole RV	1	Std
<b>Lights</b>	LED Lights (Peterson), Sealed Wiring Harness (Sealco)	1	Std
<b>Standard</b>	3/8" Safety Chains, Grade 70	1	Std
<b>Standard</b>	Heavy Duty Battery, Pump and Remote with 15ft Cord	1	Std
<b>Standard</b>	12 Volt lead with quick connector for wiring battery to tow vehicle	1	Each
<b>Trailer Color</b>	Felling Black # CCA945378 (White Felling Decal)	1	Std
<b>Standard</b>	Document Holder	1	Std
<b>Stripe Color</b>	None	1	Std
<b>GVWR</b>	19,300 lbs	1	Std