

FT-3 R		Utility Reel	
GVWR LBS: 2,990	GAWR LBS: 3,000	WEIGHT LBS: 1,100	CAPACITY LBS: 1,890

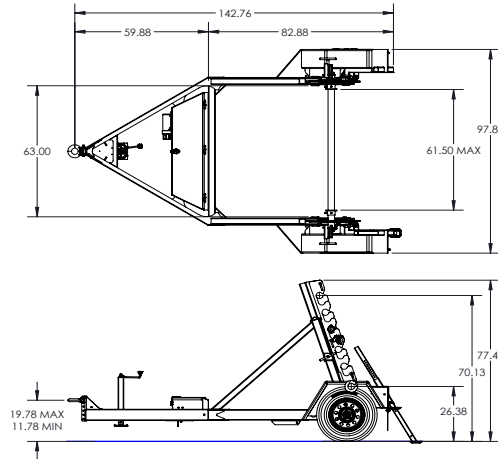

Feature Name	Standard Features	Std. Qty	UOM
Model	FT-3 R	1	
Reel Capacity	Capacity for a 61" X 120" Reel, 2.875" shaft	1	Inches
Reel Capacity	Reel Diameter at lowest position, 24" Reel	1	Std
Overall Length	Overall Length in Feet	11.5	Feet
Width	98" OD, 63" ID Approx	1	Std
Brakes	No Brakes	1	Std
Axles	3.5K Stub Axles	1	Std
Tires & Wheels	ST205/75R 15 C, 5 Bolt [15 x 6] Mod	2	Std
Hitch Type	3" Adjustable Lunette Eye/Pintle, [C] 25,000 lb, Channel Mount (5/8" Bolt)	1	Std
Jack	7K Drop Leg ** Top Wind **	1	Std
Plug	7 Pole RV	1	Std
Lights	LED Lights (Peterson), Sealed Wiring Harness	1	Std
Trailer Color	Felling Black # CCA945378 (White Felling Decal)	1	Std
Standard	Elec/Hydraulic Pump with 12 V battery in Lockable Enclosure	1	Std
Standard	3/8" Safety Chains, Grade 70	1	Std
Standard	Document Holder	1	Std
GVWR	2,990 lbs	1	Std